



Lightning and overvoltage protection



Surge Protection For Wind Turbines

JDA Auspice



ISO 9001:2008
Management
System
www.tuv.com
ID 9105078757



CONFORM TO UL1449
CERTIFIED TO CSA C22.2#8



SPD FOR WIND TURBINES



Wind turbines are in opened and exposed environment and the tall windmill is highly prone to the direct and indirect lightning damages.

The unique nature of wind power installations make them vulnerable to overvoltages and surges from lightning strikes and static discharges.

These surges need to be intercepted before they take down the entire system by damaging the wind power arrays, charge controller/inverter and combiner boxes.

JDA is a professional surge protection solution provider whom understand better for customers' needs, to design specific surge and lightning protection dedicated to wind towers that will help clients to avoid losses causing by lightning and surge damage and make their equipment safer.

Surge Protection for Power Supply

- 1 Heading protection
- 2 Control cabinet protection
- 3 Control cabinet protection
- 4 Inverter protection for rotor power supply
- 5 Control breaker protection
- 6 Engine room control cabinet protection
- 7 Rotor protection
- 8 Stator protection
- 9 Pitch system protection
- 10 Obstruction lighting protection
- 11 Anemometer protection

Surge Protection for dataline network

- 1 Pitch system communication line protection
- 2 Dataline anemometer protection
- 3 Engine room control cabinet Databus protection
- 4 Dataline or Databus protection
- 5 Modem and telephone line protection

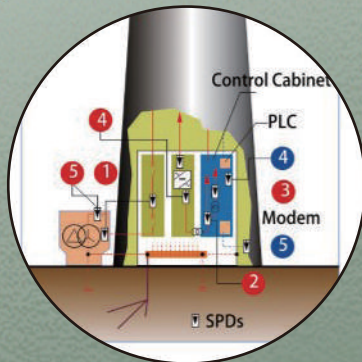
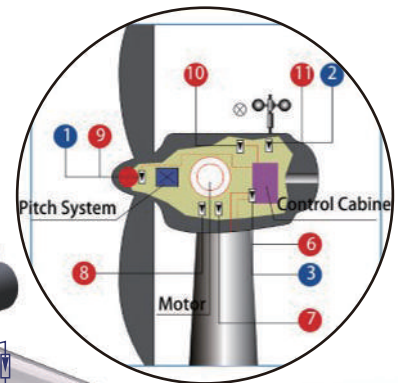

SPD's Location	JDA Models
1 4 7 8	JDA SG35-760/3P or JDA D3-40/760-3MV-R
3 10 11	JDA PV20/24-MVCR
9	JDA PV20/48-MVCR
2 5 6 9	JDA D3-40/760-3MV-R
10	JDA D1-50/440-2MV-R
1 2 3 4 5	JDA DN24/4-20mA -G JDA DN48/G, DN24/RS485 JDA DN05/RS485-2G JDA DN24/RS232-G JDA DN250/AT



SPD for power supply



SPD for dataline and phone line

Because the windmills are high and exposed outdoor, the wind turbines are highly vulnerable to the effects of direct lightning strikes, therefore we recommends to install a Type 1 SPD in the Main Switch Board. In addition, Type 2 SPDs are also required to be installed close to the sensitive equipment of the installation (like the anemometer for instance). Moreover, windmill applications are specific because many different voltages exist : 24V (for pitch system,...) 48V / 230V between Phase and Neutral, 380V / 480V / 690V or 1000V (for stator protection,...) between Phases.

Technical remarks
The wind turbine and all its equipment have to be grounded properly and, should be equipotential.

In some wind turbines, the transformer (690 / 20 000V) can be located in the nacelle. In that case, please contact us for the appropriate protection.

In case of 690V or 1000V IT network, use a 3+1 system (please consult us).

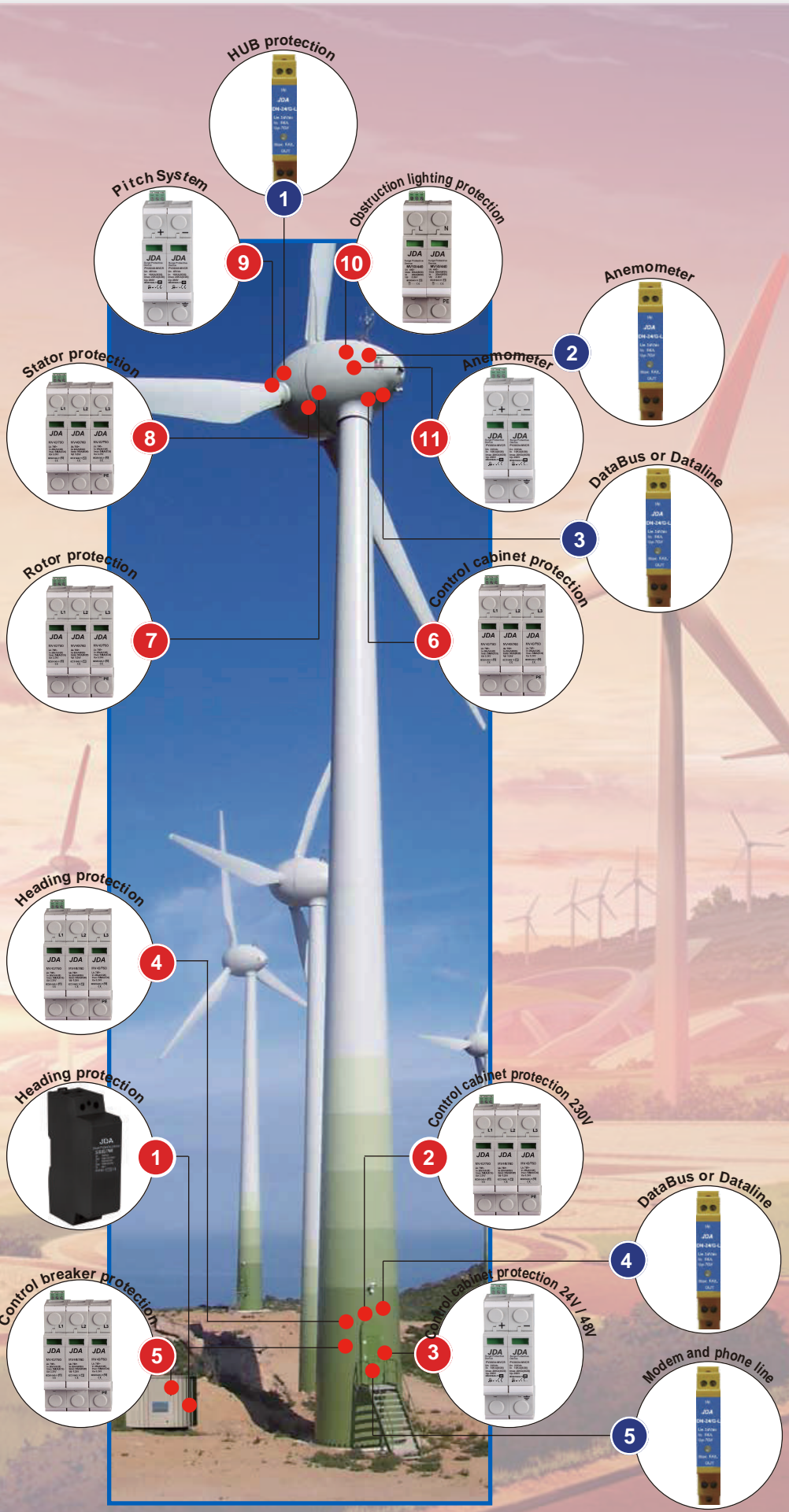

POWER SUPPLY SYSTEMS

SG35...

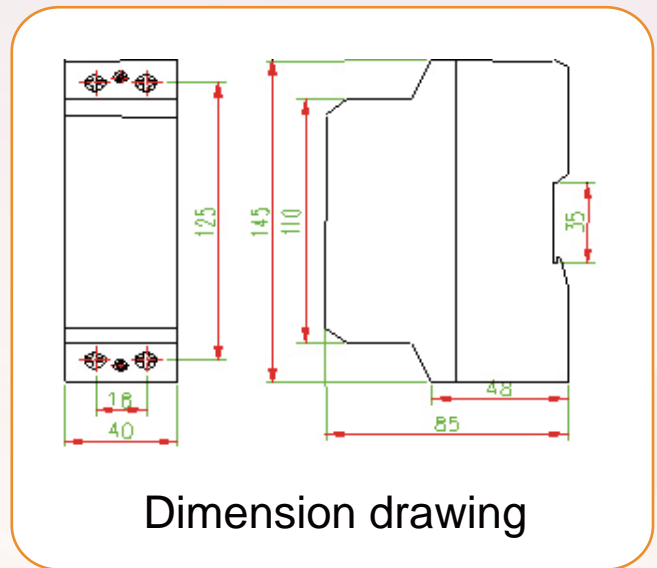

Dimension drawing

SURGE ARRESTERS – CLASS I+II

- Surge arrester for low-voltage power supply system protection against surges at the boundaries from lightning protection zone 0B -2 and higher.

Type	SG35/760-S 760
In accordance with	IEC61643-11:2013; UL1449 3 ^d
Category IEC/VDE	I+ II / B+C
Max. continuous operating voltage(V)	760Vac
Nominal discharge current(8/20) I _n	35kA
Max. discharge current(8/20) I _{max}	120kA
Lightning impulse current (10/350) I _{imp}	35kA
Voltage protection level (1.2/50)	≤4kV
Response time	≤100 ns
short-circuit current rating (I _{sc}) & follow current interrupt rating (I _{fi})	I _{sc} =10kArms ; I _{fi} ≥10kArms@255Vac
Backup fuse(only required if not already provided in)	250A gL/gG
Operating temperature range	- 40°C ~ + 80°C
Cross-section of connection wire	Single-strand 35mm ² ; multi-strand 25mm ²
Mounting	35mm DIN-rail in accordance with EN 50022/DIN46277-3
Enclosure material	thermoplastic; extinguishing degree UL94 V-0
Degree of protection	IP20
Installation width	2 modules, DIN 43880
Approvals, Certifications	CE

TYPE: D3-40/760-3MV-R

Three Phase (3 MOV Modules) Surge Protection Devices

Surge arrester for low-voltage power supply system protection against surges at the boundaries from lightning protection zone 0_B-1 and higher.

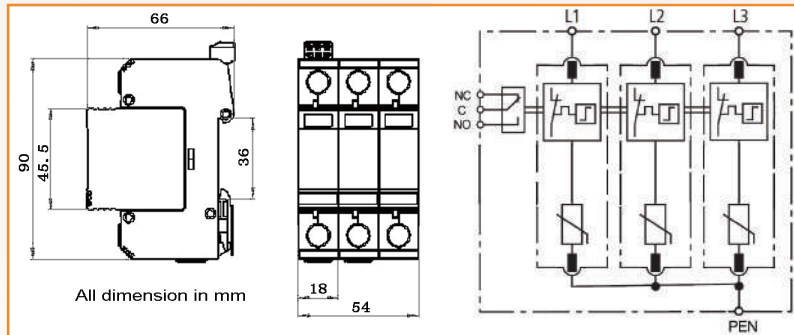

- Class II (C) arrester in accordance with IEC61643-11:2013, UL1449 3rd
- Two part design consisting of base and plug-in protection module.
- High energy MOV (Metal Oxide Varistor) inside.
- Reliable supervision due to disconnection device.
- Fault indication by red indication flag in window.
- Fast response.
- With remote alarm terminal optional.

Technical Data

Type	D3-40/760-3MV-R	
	760	
In accordance with	IEC61643-11:2013; UL1449 3rd	
Category IEC/VDE	II/ C	
Max. continuous operating voltage (AC/DC)	760/970	
Nominal discharge current (8/20) I _n (L-PE)	20kA	
Max. discharge current(8/20) I _{max}	50kA	
Voltage protection level at I _n	3.2kV	
Let through voltage @3KA (8/20)	2.5kV	
Response time	≤25 ns	
Follow current	No	
Backup fuse(only required if not already provided in mains)	125A gL/gG	
Operating temperature range	- 40°C~ + 80°C	
Cross-section of connection wire	Single-strand 35mm ² ; multi-strand 25mm ²	
Mounting	35mm DIN-rail in accordance with EN 50022/DIN46277-3	
Enclosure material	thermoplastic; extinguishing degree UL94 V-0	
Degree of protection	IP20	
Installation width	3 modules, DIN 43880	
Thermal disconnecter	Internal green – normal red - failure	
Remote alarm contact	Optional	
Additional data for Remote Alarm Contacts		
Remote alarm contact type	floating changeover contact	
Switching capability U _N /I _N	AC: 250V/0.5A DC: 250V/0.1A; 125V/0.2A; 75V/0.5A	
Cross-section of connection wire	Max. 1.5mm ²	

TYPE: D1-50/440-2MV-R

Three Phase (2 MOV Modules) Surge Protection Devices

Surge arrester for low-voltage power supply system protection against surges at the boundaries from lightning protection zone 0B-1 and higher.

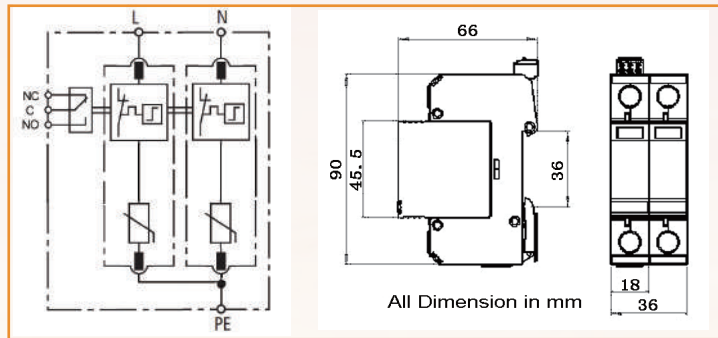

- Class II (C) arrester in accordance with IEC61643-11:2013, UL1449 3rd.
- Two part design consisting of base and plug-in protection module.
- High energy MOV (Metal Oxide Varistor) inside.
- Reliable supervision due to disconnection device.
- Fault indication by red indication flag in window.
- Fast response.
- With remote alarm terminal optional.

Technical Data

Type		D1-50/440-2MV-R	
		440	
In accordance with		IEC61643-11:2013; UL1449 3rd	
Category IEC/VDE		II/ C	
Max. continuous operating voltage (AC/DC)		440/585	
Nominal discharge current(8/20) In	L-PE	20kA	
	N-PE	20kA	
Max. discharge current(8/20) I _{max}	L-PE	50kA	
	N - PE	50kA	
Voltage protection level	@In	2.2kV	
	@3KA	1.5kV	
Response time	L-PE	≤25 ns	
	N-PE	≤25 ns	
Follow current	L-PE	No	
	N-PE	No	
Backup fuse(only required if not already provided in mains)		125A gL/gG	
Operating temperature range		- 40°C~ + 80°C	
Cross-section of connection wire		Single-strand 35mm ² ; multi-strand 25mm ²	
Mounting		35mm DIN-rail in accordance with EN 50022/DIN46277-3	
Enclosure material		thermoplastic; extinguishing degree UL94 V0	
Degree of protection		IP20	
Installation width		2 modules, DIN 43880	
Thermal disconnecter		Internal green – normal red - failure	
Remote alarm contact		Optional	
Approvals, Certifications		cETLus,KEMA,CE	



TYPE: PV20/24-MVCR



MOV Module
Surge Protection Devices for DC system
 Surge arrester for low-voltage power supply system protection against surges at the boundaries from lightning protection zone 0_B-1 and higher.

- Class II (C) arrester in accordance with IEC61643-11:2013, UL1449 3rd.
- Two part design consisting of base and plug-in protection module.
- High energy MOV (Metal Oxide Varistor) inside.
- Reliable supervision due to disconnection device.
- Fault indication by red indication flag in window.
- Fast response.
- With remote alarm terminal optional.

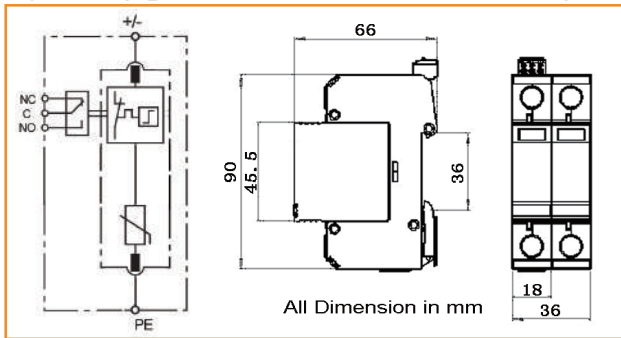

Technical Data

Type	PV20/XXX-V (-S)	
	24	48
In accordance with	IEC61643-11:2013; UL1449 3rd	
Category IEC/VDE	II/ C	
Protection mode	Common mode protection	
Nominal voltage Un (DC)	24VDC	48VDC
Max. Continuous Voltage Uc (DC)	38VDC	56VDC
Nominal discharge current (8/20) In	10kA	
Max. discharge current(8/20) Imax	20kA	
Voltage protection level at In	200V	280V
Response time	≤25 ns	
Follow current	No	
Backup fuse(only required if not already provided in mains)	125A gL/gG	
Operating temperature range	- 40 °C ~ + 80 °C	
Cross-section of connection wire	Single-strand 35mm ² ; multi-strand 25mm ²	
Mounting	35mm DIN-rail in accordance with EN 50022/DIN46277-3	
Enclosure material	thermoplastic; extinguishing degree UL94 V-0	
Degree of protection	IP20	
Installation width	2 modules, DIN 43880	
Thermal disconnecter	Internal green – normal red - failure	
Remote alarm contact	Optional	
Additional data for Remote Alarm Contacts		
Remote alarm contact type	floating changeover contact	
Switching capability UN/IN	AC: 250V/0.5A	DC: 250V/0.1A; 125V/0.2A; 75V/0.5A
Cross-section of connection wire	Max. 1.5mm ²	
Approvals, Certifications	cETLus,CE	



Terminal Block Modules series

DNxxx-G (6.2mm wide)

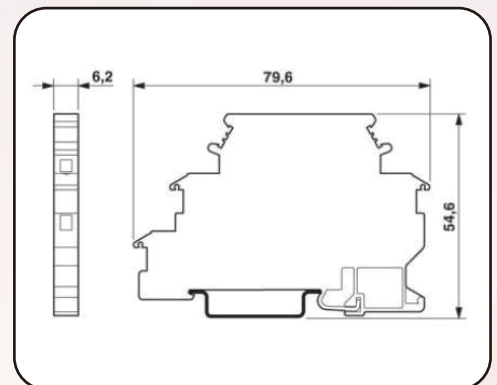
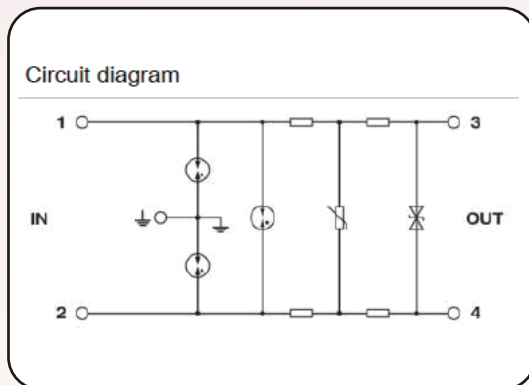

For installation at LPZ 0B-2 or higher, applied in protection for 2 single wires of balanced interfaces with measuring and controlling system, providing coarse and fine protection.

Model No		DN/12-G	DN24-G	DN48-G	DN110-G
Nominal voltage	U_N	12V	24V	48V	110V
Rated voltage (max. continuous d.c.voltage)	U_C	14V	33V	55V	170V
Rated voltage (max. continuous a.c.voltage)	U_C	9.5V	23V	38.5V	120V
Nominal current	I_L	0.5A	0.5A	0.5A	0.5A
Lightning impulse current (10/350)	per line I_{imp}	0.5kA	0.5kA	0.5kA	0.5kA
Nominal discharge current (8/20)	per line I_n	5kA	5kA	5kA	5kA
Nominal discharge current (8/20)	Total I_n	10kA	10kA	10kA	10kA
Voltage protection level at I_n	line-line U_p	$\leq 25V$	$\leq 50V$	$\leq 100V$	$\leq 260V$
Voltage protection level at I_n	line-PG U_p	$\leq 750V$	$\leq 750V$	$\leq 750V$	$\leq 750V$
Voltage protection level at $1kV/\mu s$	line-line U_p	$\leq 19V$	$\leq 45V$	$\leq 70V$	$\leq 230V$
Voltage protection level at $1kV/\mu s$	line -PG U_p	$\leq 650V$	$\leq 650V$	$\leq 650V$	$\leq 650V$
Bandwidth	line -line f_G	2.5MHz	6MHz	10MHz	16MHz
Series impedance	per line R	4.0 Ω	4.0 Ω	4.0 Ω	4.0 Ω
Capacitance	line -line C	$\leq 2.4nF$	$\leq 1nF$	$\leq 0.6nF$	$\leq 0.4nF$
Capacitance	line -PG C	$\leq 5pF$	$\leq 5pF$	$\leq 10pF$	$\leq 5pF$
Response time	line-line t_A	$\leq 1ns$	$\leq 1ns$	$\leq 1ns$	$\leq 1ns$
Response time	line-PG t_A	$\leq 100ns$	$\leq 100ns$	$\leq 100ns$	$\leq 100ns$
Operating temperature range		-40°C...+80°C			
Cross-sectional area		0.08mm ² ~ 4mm ² solid / 2.5mm ² flexible			
Mounting on		35mm DIN rail			
Enclosure material		Black thermoplastic, UL94-V0			
Test standards		IEC 61643-21			

Type: DN-xx/xxxx-2G

Surge protective devices with plug-in protection modules for high-frequency signal transmission systems against surges at the boundaries from lightning protection zone 0_B>2.

- Data network protector in according with IEC61643-21.
- Two parts design, surge protection modules to be exchanged easily.
- Limit the transients with gas discharge tubes and diodes.
- Two-stage protection circuit.
- 35 mm DIN-rail mounting design.

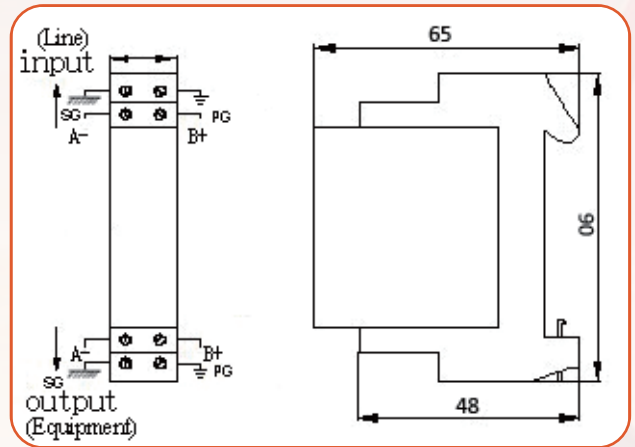
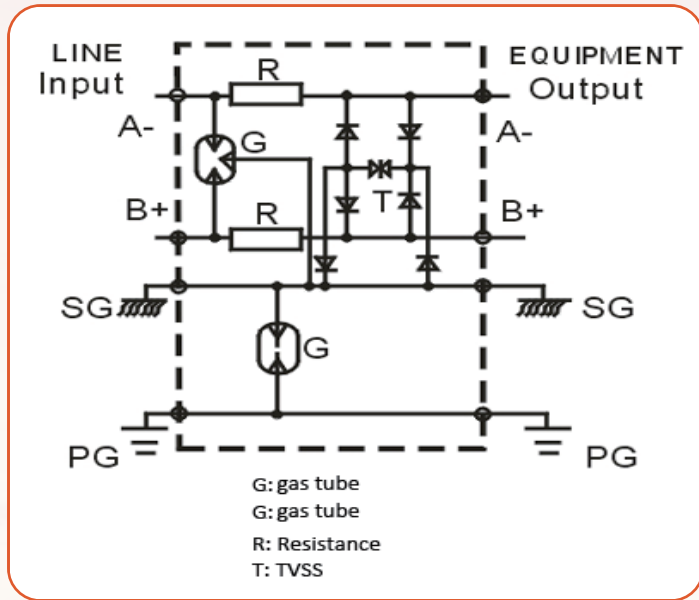

Technical Data

Model No.	DN-05/xxxx-2G
Appliance	xxxx:RS232,RS422,RS423,RS485,0/4-20mA,0-5V,0-10V
Configuration	twisted pair + shield
Nominal line voltage (Un)	5V
Max line voltage	8V
Max line current	300mA
Nominal Discharge Current(8/20μs,KA)In 10 times	10kA
Total Max. Discharge Current(8/20μs,KA)Imax 1 time	20kA
Impulse current (Iimp) (10/350us KA) impulse 2 times	5kA
Nominal Current (A) I _L	0.5A
Protection level(U _p) 8/20us impulse-5KA	35V
Series impedance per line (Ohm)	2.2 Ohm
Insertion loss at 10MHz (dB)	≤ 3.0
Degree of protection	IP20
Mounting on	35 mm DIN-rail
Enclosure Material	UL94 V0
Environment Temperature (C)	- 40~+80



Terminal Block Modules for phone line protection

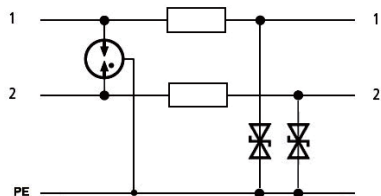

Basic circuit diagram

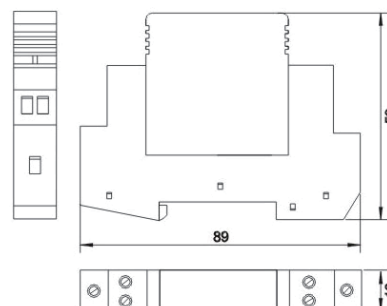

Dimension drawing

Surge protective devices with plug-in protection modules for analogue telecommunication systems against surges at the boundaries from lightning protection zone $O_B > 2$.

Technical Data

Type		DN-xxx / AT	
		110	250
In accordance with		IEC 61643-21	
Nominal voltage (Vdc)	Un	110	250
Max. continuous operating voltage (Vdc/ac)	Uc	180 / 140	280 / 190
C2 Nominal discharge current(8/20)	In	5kA	
C2 Total nominal Discharge Current (8/20us)		10kA	
Voltage protection level (V)	L-L@C2 (8/20μs)Up	≤500V	≤1000V
	L-G@C2 (8/20μs)Up	≤500	≤750
	L-L@C3 (1KV/μs)Up	≤350	≤900
	L-G@C3 (1KV/μs)Up	≤180	≤450
Nominal Current (A)	IL	0.5A	
Transmission Speed (bps)		2Mbps	
Insertion loss (dB)		≤0.5	
Series impedance per line (Ohm)		2.2 Ohm	
Protection line		One pair	
Mounting		35mm DIN-rail in accordance with EN 50022/DIN46277-3	
Type of Connection IN/OUT		screw/screw	
Dimensions (mm)		89 X 13 X 59	
Operating temperature range		- 40°C ~ + 80°C	



**Surge Protection For Wind Turbines
Lightning and overvoltage protection**



JD Auspice Co., Ltd.